



Features

- Active CCL sensor
- Detection of collars even at zero speed
- Available with or without telemetry
- High temperature – 177°C
- CANbus Interface with active termination resistor
- Highly sensitive sensor design
- Can be made with a center flow passage
- Feasible for wireline and coiled tubing
- Inductors available for ID≥25, 48 & 60mm



Product Description

The NSE CCL is an active Casing Collar Locator for downhole applications. The CCL features a sophisticated measuring principle that allows for high-resolution locator data at both high and low speeds. The sensor can detect changes in both the casing material properties and geometry. Due to its unique sensitivity it reacts to both electric and magnetic properties of the materials.

The CCL detects geometrical variations in:

- Non-magnetic, conductive materials (Austenitic stainless-steel, Aluminum, etc.)
- Conductive magnetic materials (Iron, Steel, nickel)
- Non-conductive magnetic materials (Ferrite, Magnetic powder cores, etc.)

The NSE CCL can be directly integrated into the customer's tool or used as a stand-alone unit. The CCL can stream data through the NSE telemetry system or provide data on CANbus to any third-party system with CANbus interface. Both solutions are easy to integrate into new or existing systems. The sensor may have a flow path through its center which makes it very suitable for coiled tubing applications in addition to all e-line/wireline applications. The mechanical design is compact and cost efficient.

The CCL is rated for temperatures up to 177°C (350°F) with a ruggedized design which allows for use in extremely harsh environments.

1 Product overview

The NSE CCL is available in two different board variants and multiple different inductor dimensions.

The two different circuit board variants are:

- Board variant #1 is NSE-5007-80 (MK1 – “Analog CCL”)
- Board variant #2 is NSE-5007-81 (MK2 – “Digital CCL”)

Benefits with MK2:

- Smaller size
- Higher output power capability to the inductors (15%)
- More robust CANbus
- PCBA covered with chassis
- Draws less current

The inductor variants are designed for 25mm 48mm and 60mm housing ID. Larger inductors give better sensitivity for larger casing ID.

1.1 Digital CCL versions (MK2)

Overview shows typical dimensions. Other setups can be implemented.

(Note - 36mm version use $\varnothing 25$ inductors)

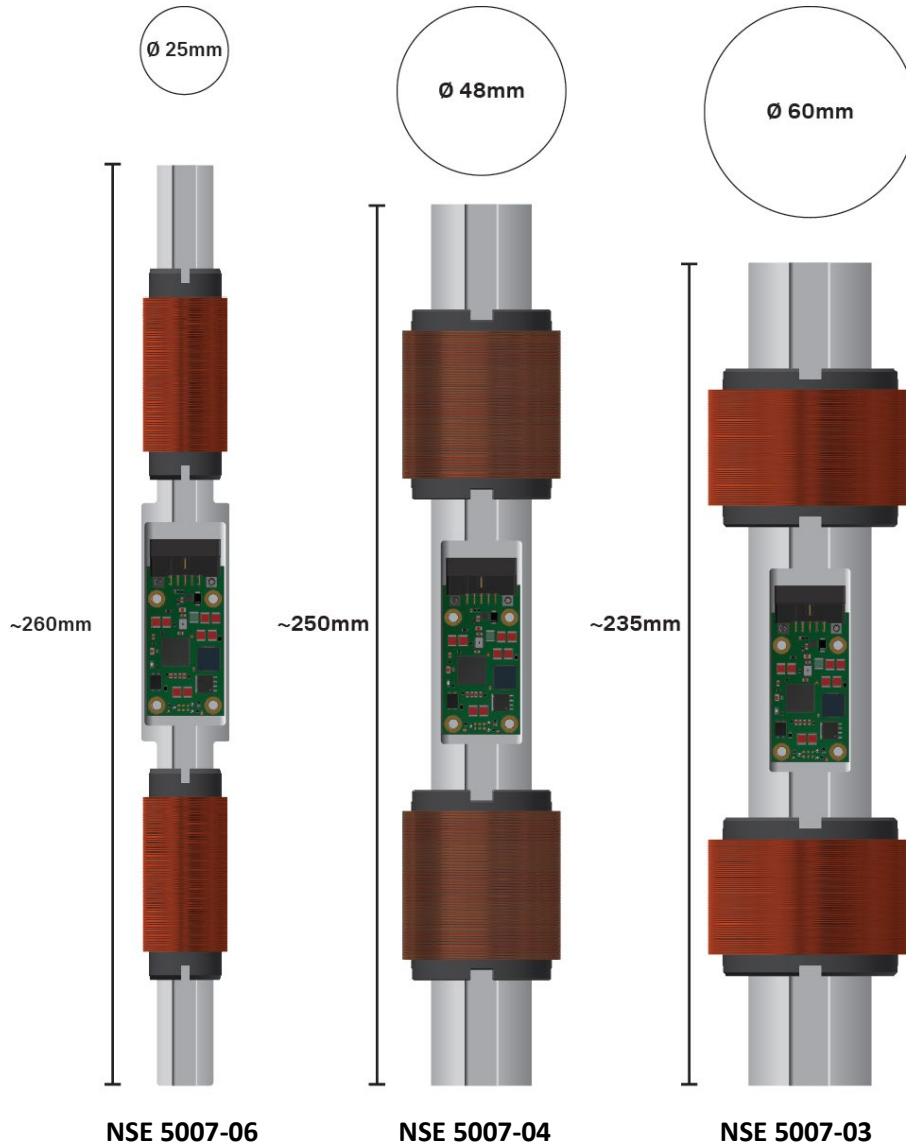

1.2 Analog CCL versions (MK1)

Overview shows typical dimensions. Other setups can be implemented.

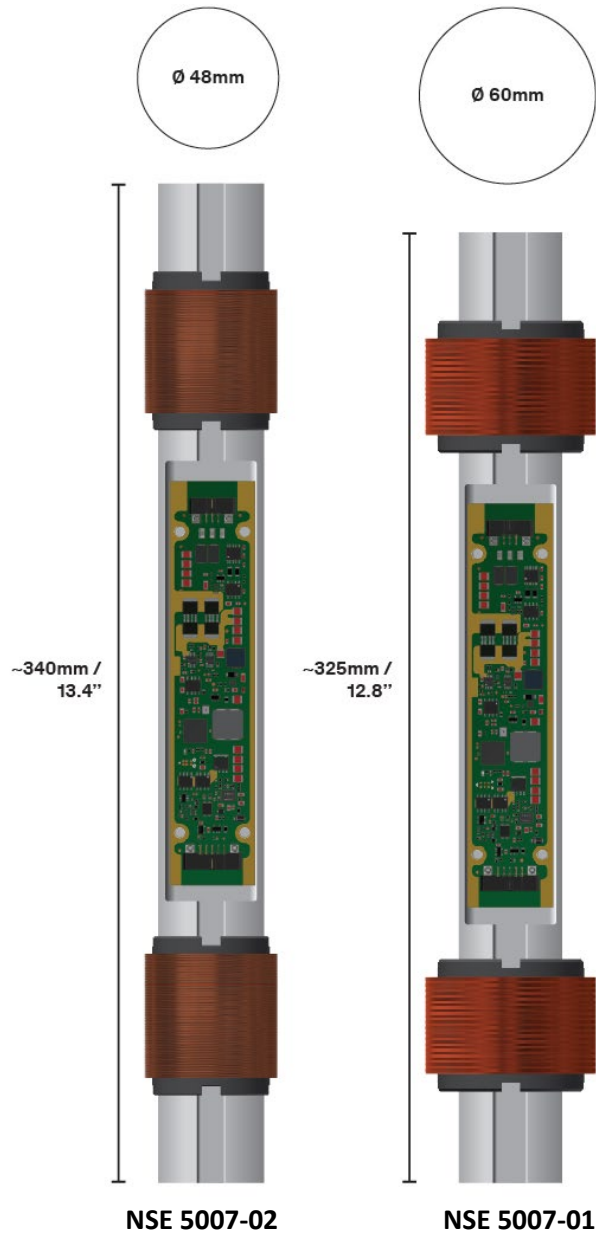

1.3 CCL for tool-integration

The standard option is that the CCL is delivered for direct tool integration.

In this configuration, NSE will provide an Inductor & PCBA kit, including the CCL processor board with housing, inductors and the wiring required to install the CCL. NSE will also provide mechanical design guidelines that describe how to design the CCL into a customer tool, including step models, mounting instructions for the inductors and material recommendations.

This makes it easy for the customer to integrate a high-performance CCL directly in their tool.

The customer will design and the tool rack/cartridge where the PCBA and inductors are mounted. The customer can mount the inductors and PCBA to their tool rack, or NSE can offer a service to assemble the CCL (The customer will then provide the rack for mounting to NSE) and do the wiring.

Note the *option 1* ordering codes for choosing between CCL for tool integration such as shown below or a setup with telemetry.

The CCL for tool integration includes the following elements:

Item	Description	Supplier
1	1 x CCL Processor Board with PCB housing	NSE
2	2 x Sensor Inductors	NSE
4	Rack/cartridge for mounting	Customer design and delivery
5	Outer housing	Customer design and delivery

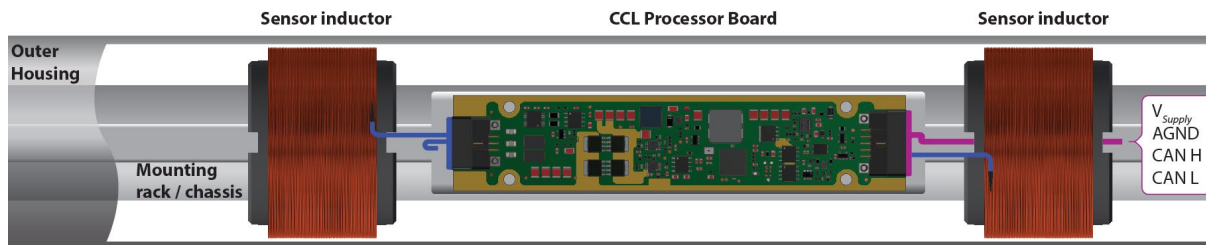

1.4 CCL with integrated DH Telemetry and HV Power Supply

This configuration consists of the CCL PCBA and Inductor kit + the NSE DH telemetry with PSU – NSE-5004-16. In this configuration, the CCL can be connected directly to the wireline and act as a stand-alone CCL – sending its data to an NSE topside modem.

The NSE modem with integrated PSU will provide power to the CCL and transfer data back to the topside modem. An NSE topside modem is required to receive the data. The modem with the integrated power supply requires 100Vdc input voltage as a minimum and will work up to 600Vdc input.

The outer chassis is customer design/provided item but must follow the NSE guidelines for materials and layout.

Refer to NSE-5004-16 (downhole modem) datasheet for information about voltage levels and data capacities.

Note the *option 1* ordering codes for choosing between CCL for tool integration or a setup with DH telemetry.

The CCL with integrated DH Telemetry and HV Power Supply includes the following elements:

Item	Description	Supplier
1	1 x CCL Processor Board	NSE
2	2 x Sensor Inductors	NSE
3	1 x NSE DH telemetry with PSU – NSE-5004-16	NSE
4	Chassis/rack for mounting PCBA and inductors	Customer design
5	Outer housing	Customer design

Topside of mounting rack / chassis:

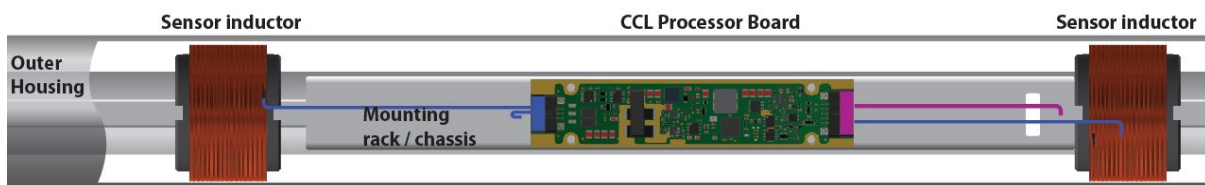

Bottom side of mounting rack / chassis:

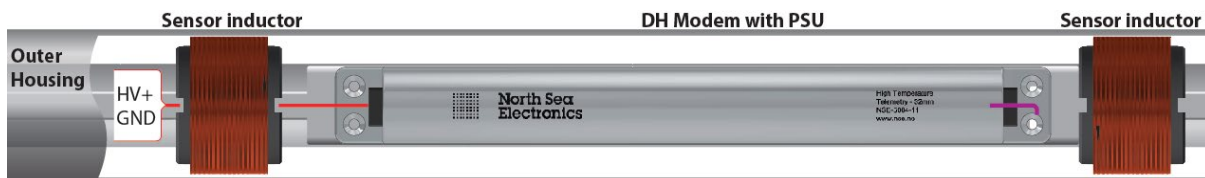

2 Product Specification

Parameter	Conditions / Comments	Min	Typ	Max	Unit
SUPPLY VOLTAGE Input Voltage Range Power consumption	<i>CCL for integration (CANbus)</i> <i>Specified operational range</i> <i>18 – 30Vdc Input voltage</i>	18	24 1	48 3	Vdc W
CCL Data <i>Sensing Method</i> <i>Response time Min -> Max</i> <i>Response time Max -> Min</i>	 <i>10-90% Full Scale output change</i> <i>90-10% Full Scale output change</i>		INDUCTIVE 10 100		 <i>ms</i> <i>ms</i>
SAMPLE RATE Output Data rate	<i>Through CANbus</i>		50	100	Sps
CANBUS INTERFACE* Bit Rate		83.3	125	250	kbits/s
ENVIRONMENTAL AND THERMAL Ambient temperature	<i>Min and Max Temperature on the surface of outer housing</i>	-10		177	°C
OPERATIONAL LIFETIME <i>Expected Lifetime</i>	<i>< 125°C Ambient Temperature</i> <i>125 - 150°C (4 x acc. factor)</i> <i>150- 177°C (8 x acc. factor)</i>	2000 500 250			<i>Hours</i> <i>Hours</i> <i>Hours</i>

* Note – Bit rate is configurable.

3 Thermal properties

The NSE High-Temperature Casing Collar Locator is designed to operate in environments with up to 177°C ambient temperatures.

In a typical assembly, the **NSE UNIT** is mounted to a **MOUNTING PROFILE** that is located inside an **OUTER HOUSING**.

The **OUTER HOUSING** surface temperature should not rise above the specified maximum ambient temperature, and the mechanical design and interface between the **OUTER HOUSING**, **MOUNTING PROFILE** and the **NSE UNIT** should have a low thermal resistance.



3.1 Conformal Coating

This product is delivered without conformal coating of the electronics. However, this can be provided on request.

3.2 Environmental requirements

NSE boards must be installed in atmospheric pressure (1atm) with dry air. Avoid any humid atmosphere or under- /overpressure. Refer to general NSE installation guidelines for more information.

4 NSE CCL advantages

The NSE CCL can detect even very tiny geometrical changes on a casing. Setting the CCL in different modes allow for optimized performance in different scenarios and conditions (various casing diameters, materials and how the CCL is run in the hole).

For most scenarios, the CCL will perform excellent with the standard settings / mode, but various configurations can be used to optimize a job.

4.1 Sensitivity and low noise

When tested and compared to a legacy CCL, the NSE CCL will typically exhibit a lower background noise and provide better sensitivity. In particular this can be seen when the CCL is either run slowly across a collar or it is offset from the casing wall.

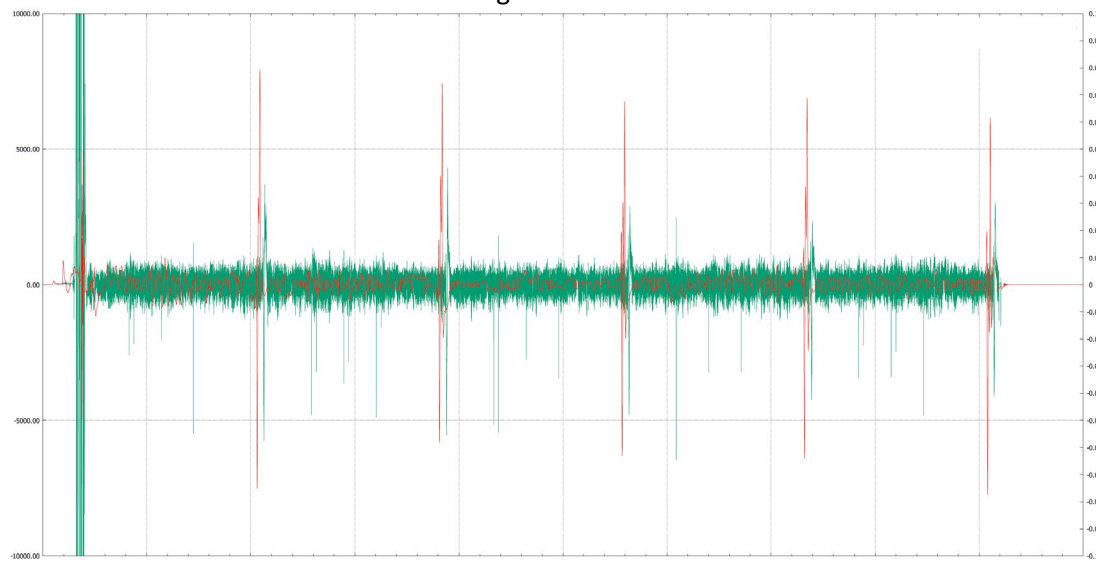

7" centralized data (CCL is lifted ~1.5" from casing) – 5 foot/min
 Red graph – left Y axis - NSE active CCL
 Green graph – right Y axis – Standard industry CCL



13 3/8 and 9 5/8" centralized data (CCL is lifted ~1.5" from casing) – 5 foot/min
 Red graph – left Y axis - NSE active CCL
 Blue graph – right Y axis – Standard industry CCL

4.2 Difference in output signal vs. speed

The NSE CCL output does not scale with the speed – meaning the output signal has a near constant amplitude independent of the speed of which is passed the collar. The legacy CCL scale its amplitude depending on the speed.

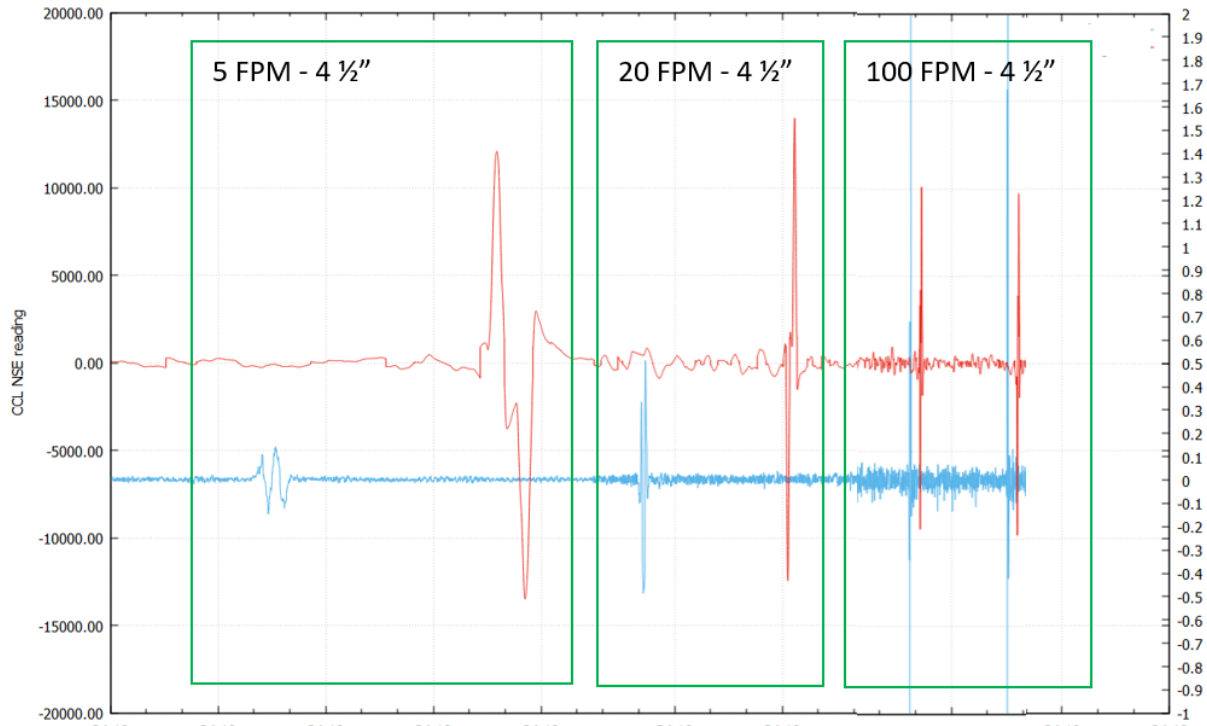

4 1/2" data for various speeds.

Red graph – left Y axis - NSE active CCL

Blue graph – right Y axis – Standard industry CCL

4.3 Detection of stainless steel

The NSE CCL operates without the use of permanent magnets or the creation of a magnetic field to detect collars. Instead, it utilizes an innovative measurement technique that detects discontinuities on the surface, such as casing collar joints. This unique mode of operation enables the NSE CCL to detect collars made from stainless steel and other materials typically undetectable by traditional CCLs.

4.4 Digital output

The NSE CCL output data directly on CANbus. This allow for easy integration into telemetry systems and precise presentation of data in a user interface. The CANbus interface also allow for configurations of the CCL, including gain adjustments, mode settings, output data rates and other parameters that can be used to optimize the CCL for a job. All settings are stored in a non-volatile memory.

The NSE CCL outputs data directly via CANbus, facilitating seamless integration into telemetry systems and ensuring precise data presentation in user interfaces. The CANbus interface also allows for comprehensive configuration of the CCL, including gain adjustments, mode settings, output data rates, and other parameters. These settings enable the optimization of the CCL for specific jobs. Configuration settings are stored in non-volatile memory."

4.5 Features

Feature	Description
Communication Interface	<p>The CCL is delivered with either NSE DH Telemetry or with CANbus communication interface.</p> <p>The unit has CANbus termination that can be enabled or disabled in firmware.</p>
Wide input voltage range	The CCL will accept input voltages from 18 to 48Vdc.
High sensitivity	The CCL uses a proprietary measurement principle that enables high sensitivity and detection of collars even if the unit is not moving.
High output data rates	The CCL can stream output data at up to 100samples per seconds – allowing for precision measurements even if the unit is traveling at high speeds.
Variable gain and sensitivity	Gain and sensitivity can be changed by sending commands to the unit to optimize performance for various scenarios and casing diameters.
Temperature sensing	<p>There is an embedded temperature sensor on the board.</p> <p>Temperature can be read out through the CAN communication interface.</p>

5 Connector and pin-outs

Note that the two board variants has different connector pinouts.

Board variant #1 is NSE-5007-80 (MK1) – Used in NSE-5007-01/02.

Board variant #2 is NSE-5007-81 (MK2) – Used in NSE-5007-03/04/05/07

Descriptions of these are given below.

5.1 NSE-5007-01/02 - “CCL MK1”

5.1.1 Power and communication

This describes the connector interface to board type NSE-5007-80 (MK1)

CCL PCBA Connector: M80-5401042

Mating connector: M80-4611042

Mating connector with flying leads: M80-FE21068F2-0450L or M80-FF21068F2-0450L

Pin	Signal name	Description / Function	PCBA Connector Pinout
1	V_Supply	Input Power	
2	AGND	Ground	
3	N.C	Not Connected	
4	CAN H	CAN High	
5	CAN L	CAN Low	
6	TEST 1	Test pin – Not to be connected	
7	N.C	Not Connected	
8	N.C	Not Connected	
9	CAN H	CAN High	
10	CAN L	CAN Low	

5.1.2 Sensor (inductors)

CCL PCBA Connector: M80-5400642

Mating connector: M80-4610642

Mating connector with flying leads: M80-FE20668F2-0450L or M80-FF20668F2-0450L

Pin	Signal name	Description / Function	PCBA Connector Pinout
1	SIG-	Inductor 1 Driver	
2	SIG+	Inductor 2 Driver	
3	COM+	Inductor 2 Common	
4	COM-	Inductor 1 Common	
5	GND	GND	
6	TEST2	Diagnose (Not to be connected)	

Use 0.5Nm torque on the connector securing screws.

5.2 NSE-5007-03/04/05/06 - “CCL MK2”

5.2.1 Power, communication & sensor

This describes the connector interface to board type NSE-5007-81 (MK2)

The NSE-5007-03 has only one PCBA plug interface. The same signals are supported on this interface as on the NSE-5007-01/02 version, except some duplicated signals are removed.

CCL PCBA Connector: M80-5401042
 Mating connector: M80-4611042
 Mating connector with flying leads: M80-FE21068F2-0450L or M80-FF21068F2-0450L

Pin	Signal name	Description / Function	PCBA Connector Pinout
1	V_Supply	Input Power	
2	AGND	Ground	
3	SIG-	Inductor 1 Driver	
4	SIG+	Inductor 2 Driver	
5	COM-	Inductor 1 Common	
6	COM+	Inductor 2 Common	
7	TEST 1	Test pin – Not to be connected	
8	N.C	Not Connected	
9	CAN H	CAN High	
10	CAN L	CAN Low	

6 Firmware

The embedded firmware features all the necessary functions to set up and run the CCL. Basic setup will cover the most common use of the CCL, but changing parameters such as amplitude gain and frequency is easy and can be done on the fly if required.

Setup of the controller is stored in a non-volatile memory that can also easily be down- and uploaded to a computer to save and restore defined configurations.

6.1 Control parameters

Parameter(s)	Setting(s)
Mode setting	Different mode setting allows for different behavior of the CCL. The parameters below (Gain, offset, frequency and thresholds) are set to pre-defined levels depending on desired behavior. Manual control of the parameter is also possible if required.
Amplitude gain	Changing the amplitude gain of the CCL.
Amplitude offset	Changing the offset can be used to cancel out effects of the mechanical design on the CCL.
Frequency	The CCL excitation frequency can be changed in order to tune its performance for different scenarios. Consult NSE for use of this parameter.
Communication	Bit rate, node ID
Squelch Threshold	Noise attenuation level
Other Parameters	Other control and configuration parameters. Refer to register description for a full overview of parameters

6.2 Feedback parameters

Parameter(s)	Readout
Signed Amplitude	CCL detection signal
Temperatures	Internal board temperatures
Other Parameters	Other feedback parameters. Refer to register description for a full overview of parameters

6.3 Bootloader

The controller is provided with a bootloader that allows for easy updates of the firmware. NSE is constantly making improvements and adding features to its firmware-base and the bootloader allows the customer to upgrade a controller if desired.

7 Graphical User Interface

The “NSE Node Manager” software (graphical user interface) is a free of charge software that can be used to set up and run the sensor. This software uses the standard NSE protocol to communicate with the casing collar locator and allows the user to set up and run the system within minutes.

A USB to CANbus adapter is required to communicate between “NSE Node Manager” software and CCL sensor.

8 Mechanical Design

See document “NSE-500701-904 – NSE CCL - Mechanical Design Guidelines” for information about the mechanical design of chassis and housing.

8.1 Analog PCBA (CCL MK1)

8.1.1 Dimensions Model -01, OD=60mm (Analog PCBA – MK1)

Note – final dimensions depend on customer design and layout. The drawing below can serve as a reference for typical dimensions.

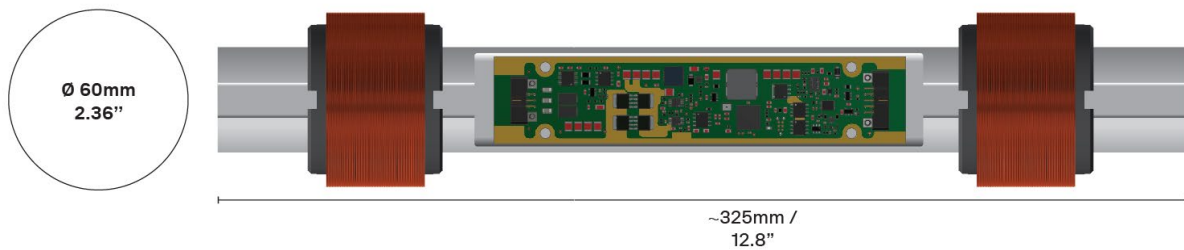

8.1.2 Dimensions Model -02, OD=48mm (Analog PCBA – MK1)

Note – final dimensions depend on customer design and layout. The drawing below can serve as a reference for typical dimensions.

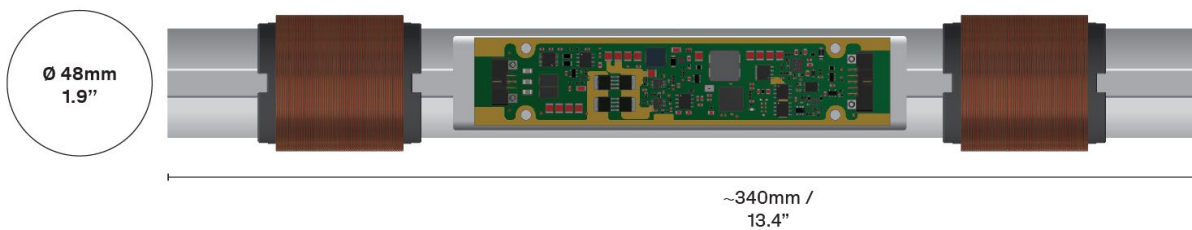

8.2 Digital PCBA (MK2)

8.2.1 Dimensions Model -03, OD≥60mm (Digital PCBA – MK2)

Note – final dimensions depend on customer design and layout. The drawing below can serve as a reference for typical dimensions.

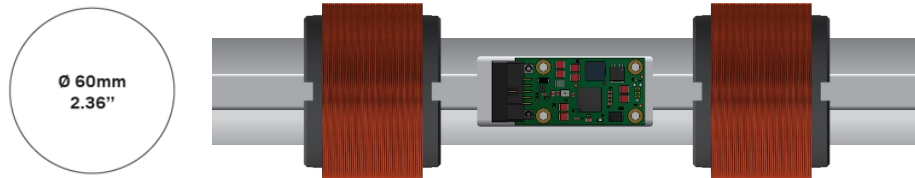

8.2.2 Dimensions Model -04, OD≥48mm (Digital PCBA – MK2)

Note – final dimensions depend on customer design and layout. The drawing below can serve as a reference for typical dimensions.

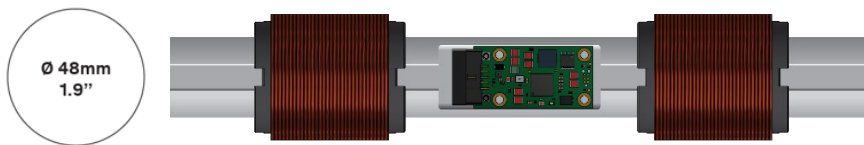

8.2.3 Dimensions Model -06, OD≥25mm (Digital PCBA – MK2)

Note – final dimensions depend on customer design and layout. The drawing below can serve as a reference for typical dimensions.

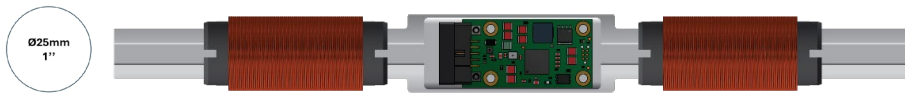

8.2.4 CCL housing for MK2 (Digital PCBA)

Unless otherwise specified (note the ordering codes) – the Digital CCL PCBA will be delivered in a housing (Ordering Code Option 2 – X).

Housing dimensions are 62.5 x 25 x 13mm, and there are 4 x M3 mounting holes. Step files can be provided on request.

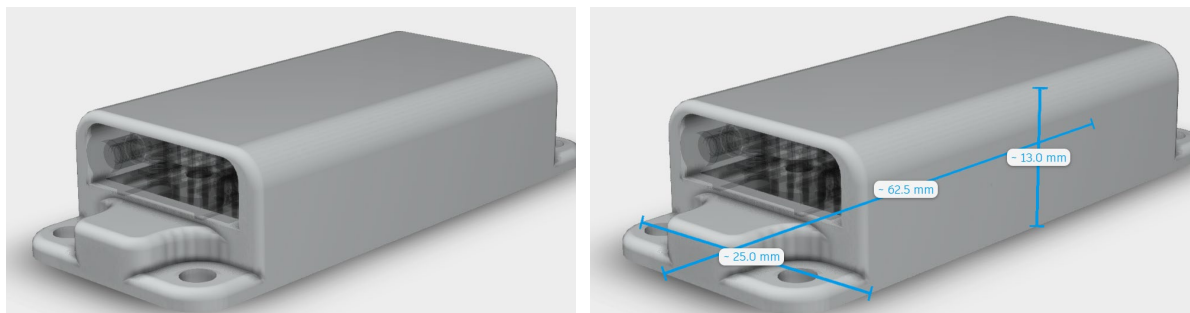

8.3 Inductor dimensions

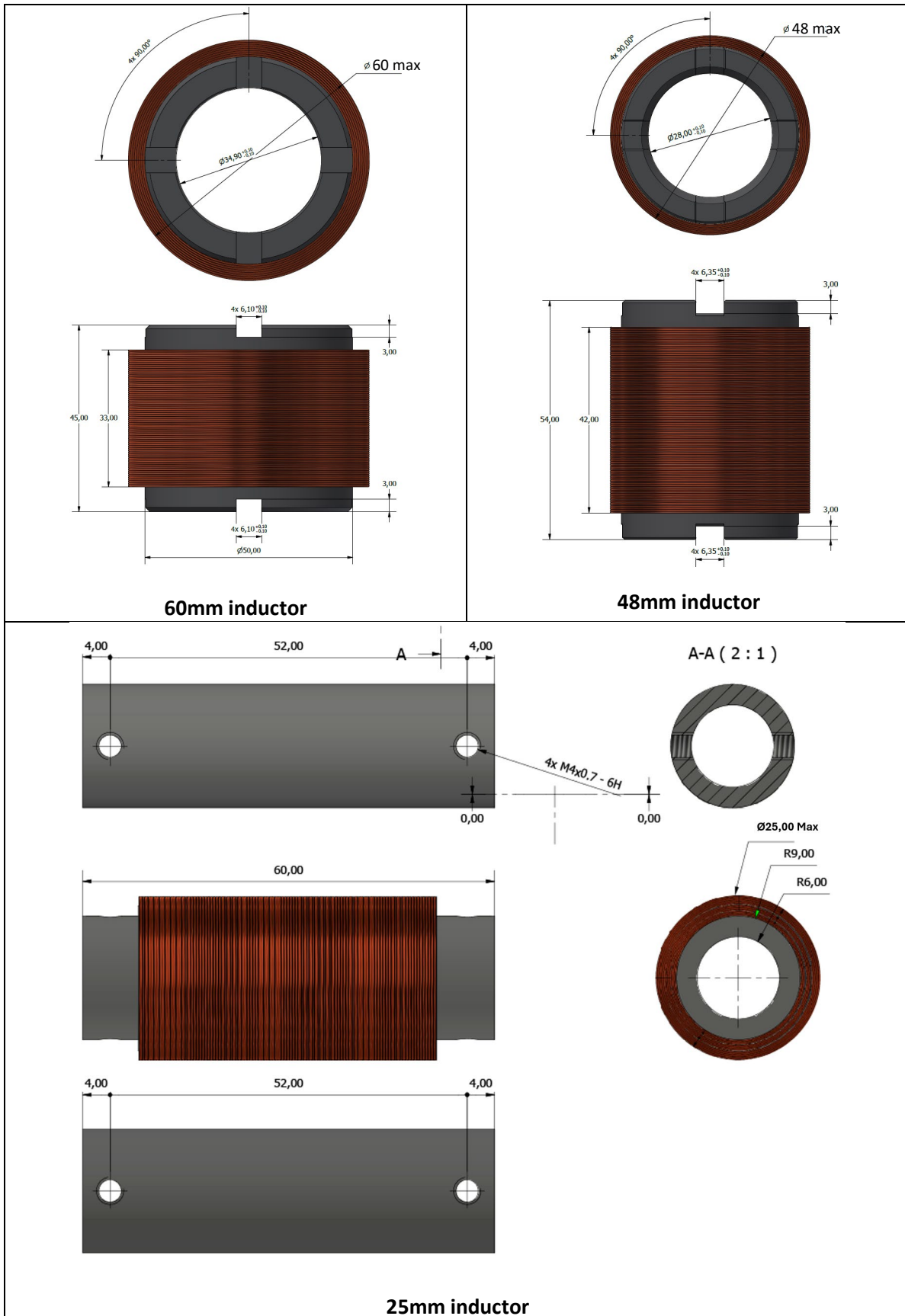

9 Ordering

9.1 Order code

		Order code:	NSE-5007	-XX	-N	-N
Category	NSE-5007	= NSE CCL				
Model	-01	Inductor OD=60mm, Analog				
	-02	Inductor OD=48mm, Analog				
	-03	Inductor OD=60mm, Digital (MK2)				
	-04	Inductor OD=48mm, Digital (MK2)				
	-06	Inductor OD=25mm, Digital (MK2)				
Option 1	A	Inductor & PCBA kit.				
	B	Inductor & PCBA kit incl. downhole Telemetry (NSE-5004-16)				
Option 2	A-U	Customer specific configurations				
	Y	Retrofit PCBA housing (no flanges)				
	X	Standard PCBA housing (with flanges)				
	Z	No PCBA housing.				

9.2 Where to buy

Email: sales@nse.no
 Web: www.nse.no
 Phone: +47 406 48 400

10 Datasheet revisions

REV	DATE	DESCRIPTION	PREP	APPR
A	19.03.2021	Initial release	RFY	GLK
B	29.06.2022	Changed mating connectors	EEN	RFY
C	04.07.2023	Updated with MK2 versions	AJA	GLK
D	19.09.2023	Including MK2 plug description. Various adjustments. Corrected document number.	TKK	GLK
E	01.11.2023	Fixed typo on pin numbers on connector	TKK	GLK
F	06.11.2023	Added alternative connector with flying leads	AJA	GLK
G	05.08.2024	Updated option codes Updated descriptions of the CCL.	GLK	RFY
H	31.10.2024	Updated inductor dimensions	RFY	GLK
I	22.11.2024	Updated MK2 vs MK1 benefits	TKK	GLK
J	26.11.2024	Updated physical dimensions of inductors	PLY	GLK
K	24.01.2025	Updated Option code 2. PCBA housing types.	VVR	GLK

